

## sextant

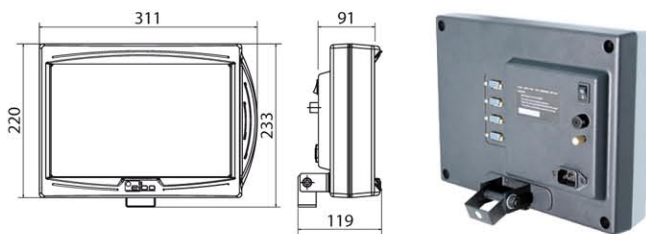

PESO - WEIGHT - GEWICHT: 2,5 kg

ALIMENTAZIONE - POWER SUPPLY - ELEKT. SPEISUNG:  
115 + 230 VAC; 50-60 Hz; 30 VA

## LEO

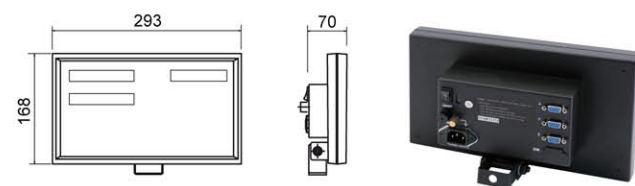

PESO - WEIGHT - GEWICHT: 2,5 kg

ALIMENTAZIONE - POWER SUPPLY - ELEKT. SPEISUNG:  
115 + 230 VAC; 50-60 Hz; 30 VA

## evm/evtm/vis

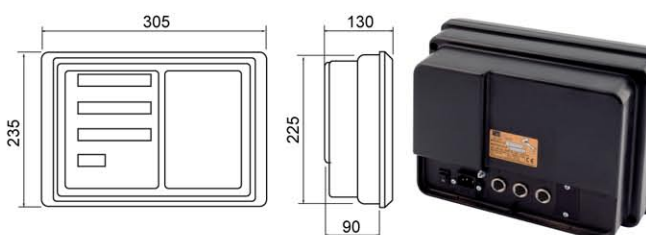

PESO - WEIGHT - GEWICHT: 2,0 kg

ALIMENTAZIONE - POWER SUPPLY - ELEKT. SPEISUNG:  
115 + 230 VAC; 50-60 Hz; 30 VA

## genius

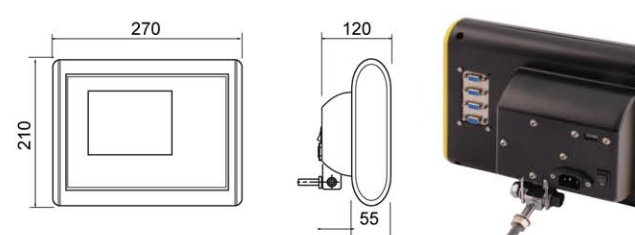

PESO - WEIGHT - GEWICHT: 5,0 kg

ALIMENTAZIONE - POWER SUPPLY - ELEKT. SPEISUNG:  
220 V o 110 V; 50 Hz o 60 Hz; ~ 20-30 Watt

### COMPLEMENTI DI SERIE STANDARD COMPLEMENTS STANDARD ZUBEHÖR

Supporto snodato per Sextant e Leo  
Snodable support for Sextant and Leo  
Gelenk-Halterung für Sextant und Leo



Cavi e manuale d'uso  
Cables and the instruction manual  
Anschlussleitungen und Handbuch herunter

### OPTIONAL



Supporto snodato  
Snodable support  
Gelenk-Halterung

EREDI BASSI ARALDO di Bassi R. sas  
Strumenti di misurazione e metrologia

Sede legale  
Via della Repubblica 2- 40013  
Castel Maggiore (Bologna) Italy  
P.I. 01950341204

Amministrazione e laboratori  
Via G. Leopardi 5c  
Castello d'Argile fraz. Mascarino (Bologna)  
Tel. +39 051 766226  
Fax +39 051 765352  
info@elboitaly.it  
www.elboitaly.eu

**elbo**<sup>®</sup>  
EREDI BASSI ARALDO SAS  
Bologna Italy

### CARATTERISTICHE GENERALI:

Modelli brevettati.  
Il robusto corpo, completamente sigillato,  
evita qualsiasi intrusione ed assicura  
un'elevata protezione ai disturbi  
elettromagnetici.

### GENERAL FEATURES:

Patented models.  
The rugged body, completely sealed to  
prevent any intrusion and ensures high  
protection against electromagnetic  
interference.

### GENERAL FEATURES:

Patentierte Modelle.  
Das robuste Gehäuse, komplett  
abgedichtet jedes Eindringen zu verhindern  
und sorgt für hohen Schutz gegen  
elektromagnetische Störungen.

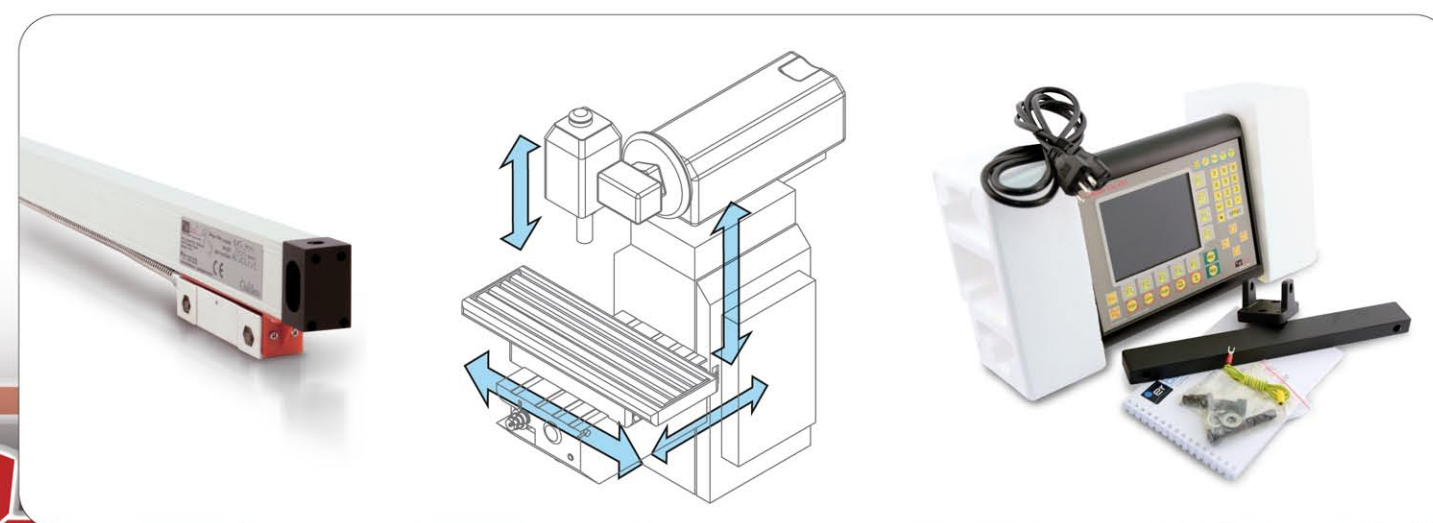

02

Strumenti di misurazione e Metrologia



**elbo**<sup>®</sup>

Bologna Italy

EREDI BASSI ARALDO SAS



CE

frese e alesatrici  
milling and boring machines  
fräsesmaschinen und bohrmaschinen



